

Montageanleitung / Manual
 Las instrucciones de instalación
 Les instructions d'installation
 Istruzioni per l'uso / Asennusohjeet

SL 790

Lichtsystem / Lighting system
 Sistemas de luz / Système lumineux
 Sistema da incasso / Valaisinjärjestelmä

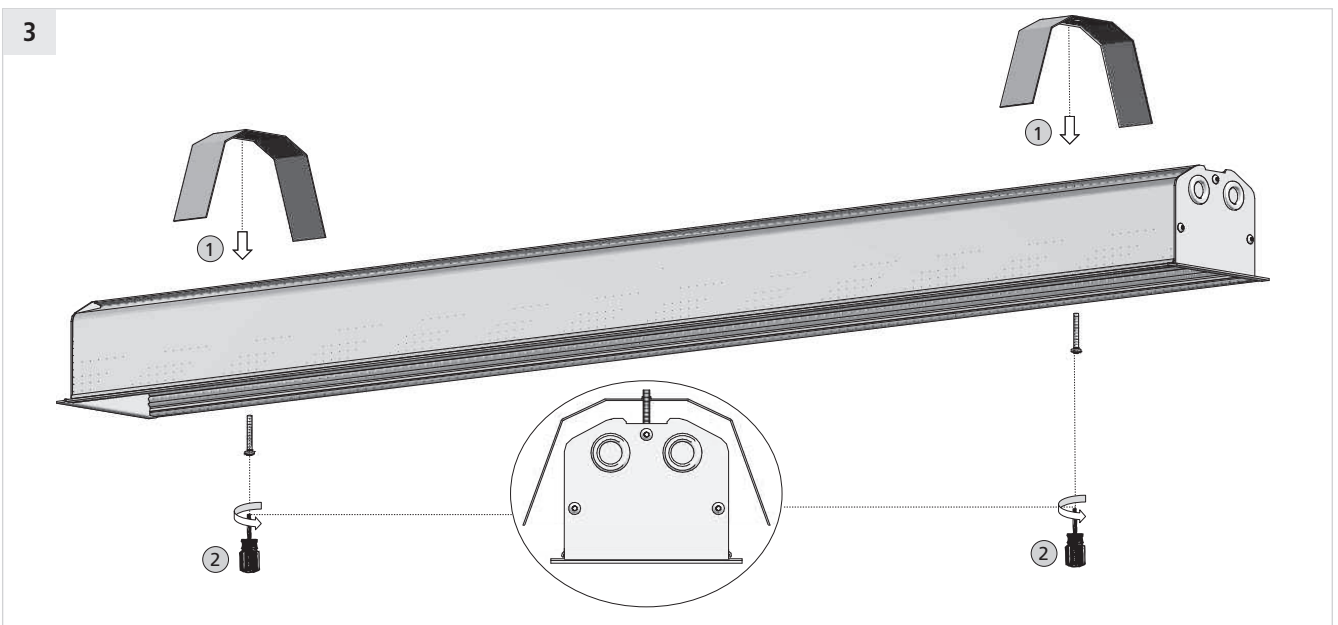

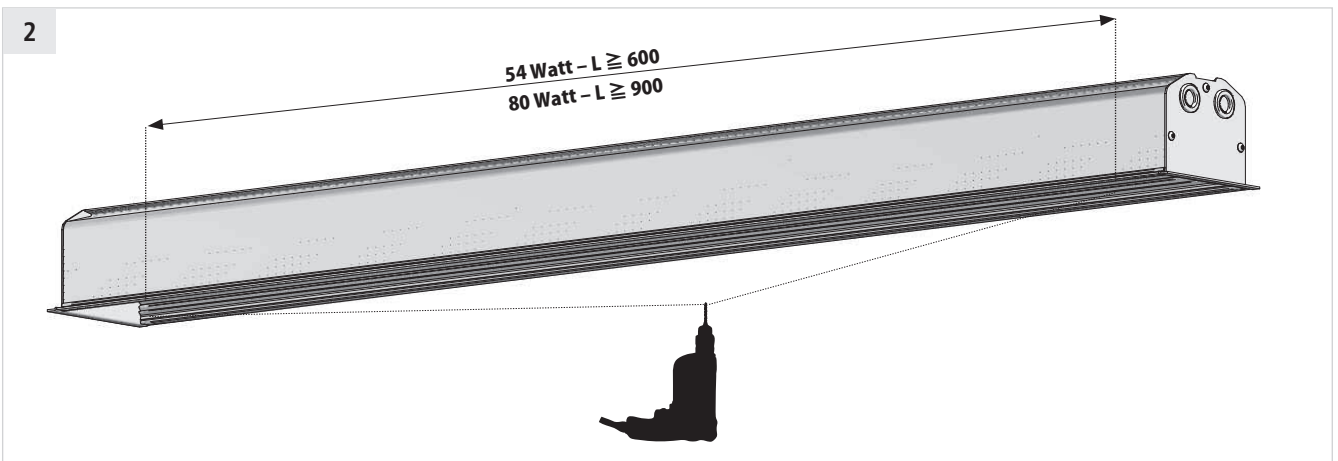
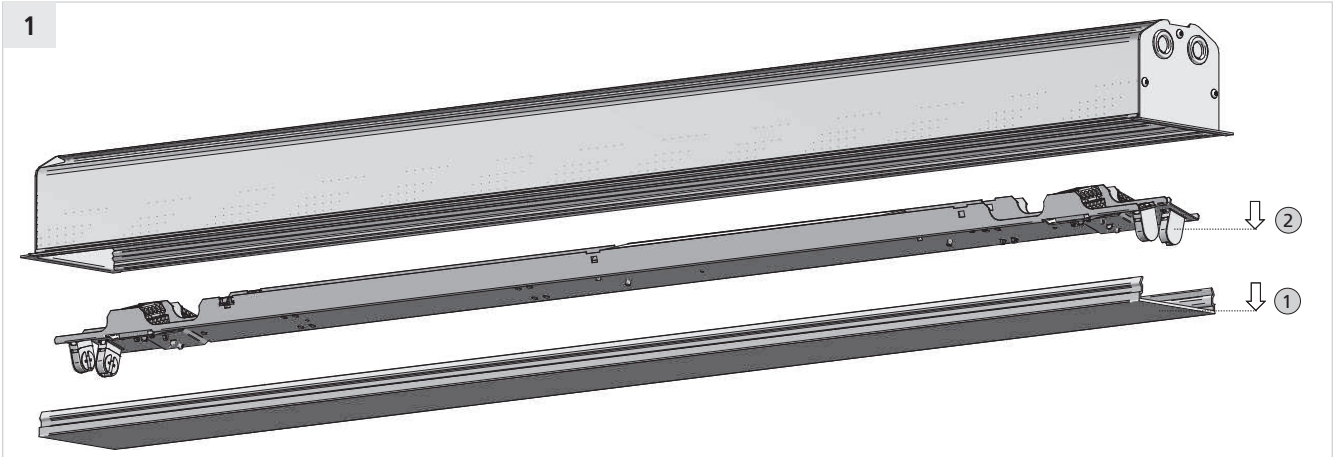
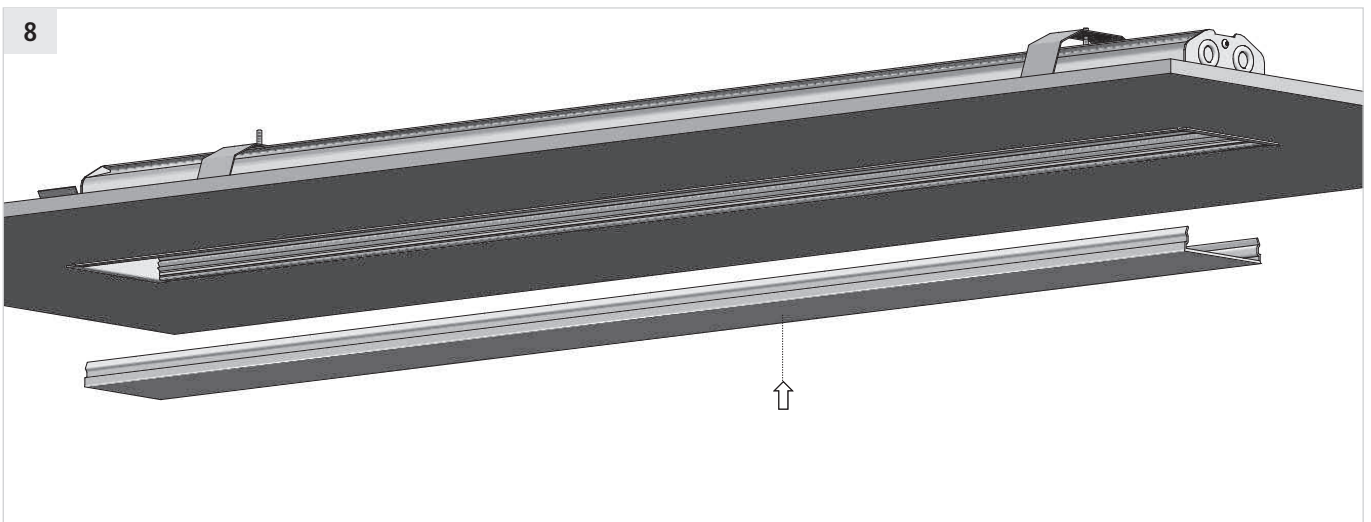
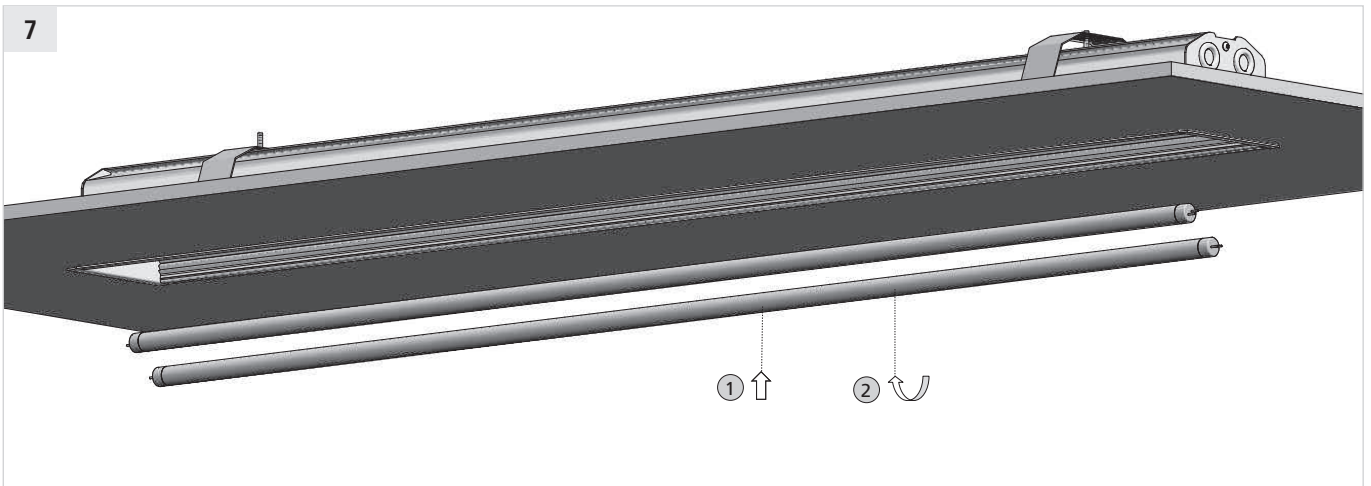
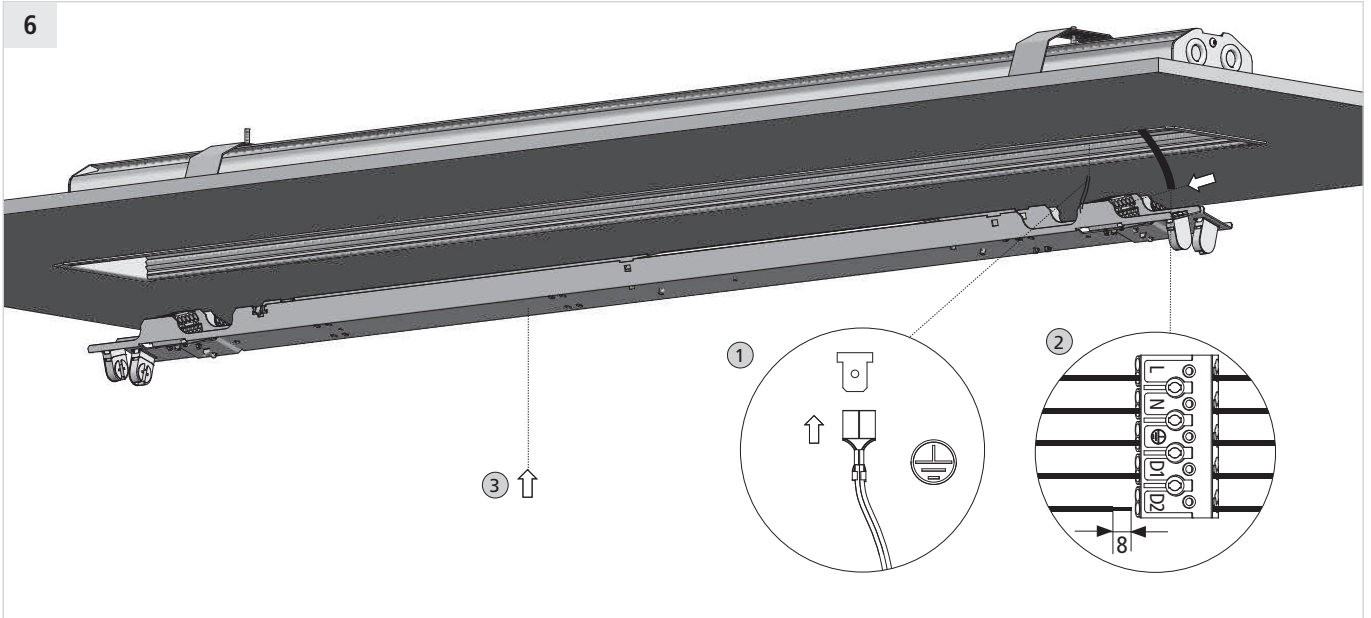
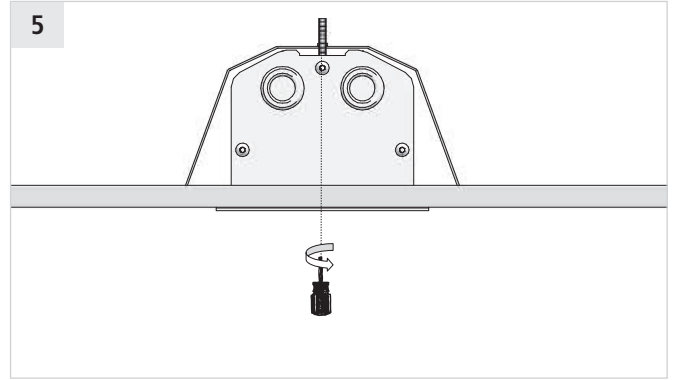
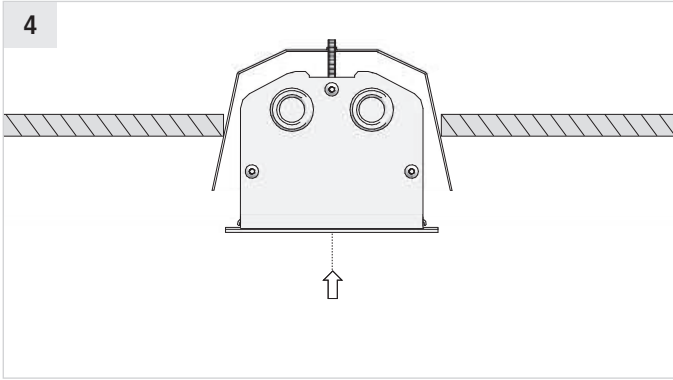

Lichtbandmontage
Continuous mounting
Montaje en línea continua

Montaggio in fila continua
Montage en ligne continue
Jonoasennukseen

1

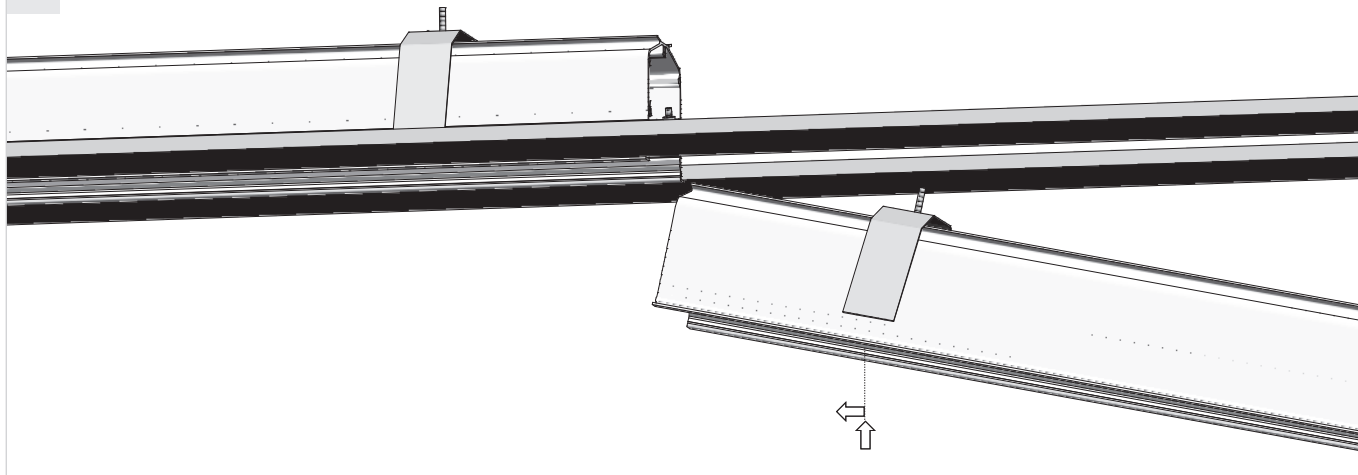

2

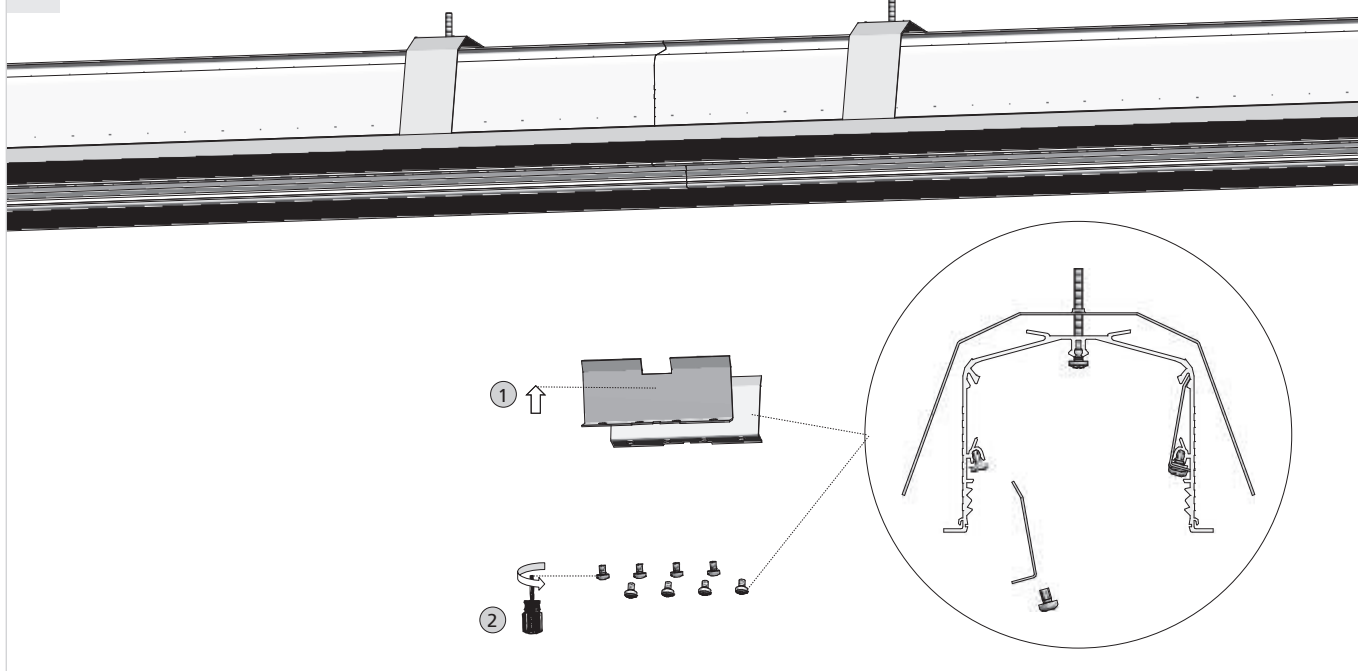

3

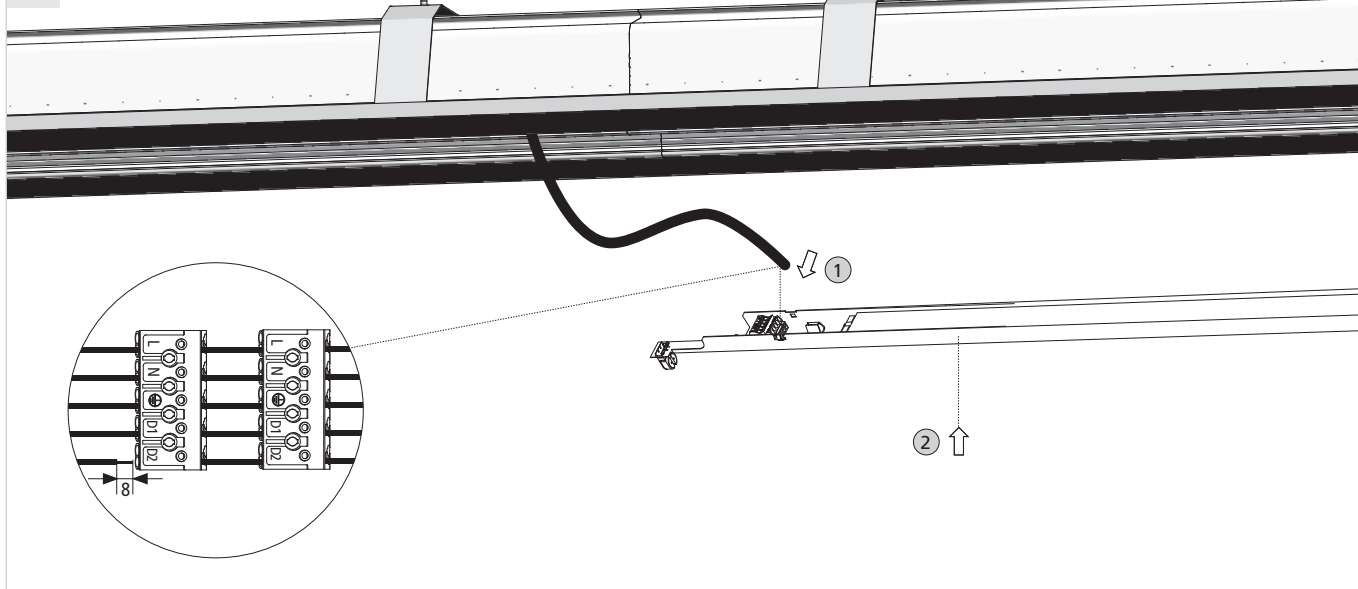

Anschlusschema
Wiring scheme

Schéma de raccordement
Kytentäkaavio

EVG
HF ballast
Balasto electrónico
Ballast électronique
Reattore elettronico
HF-liitäntälaite

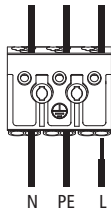

Notlicht mit Batterie
Emergency kit with battery
Equipo de luz de emergencia
Kit di emergenza
Kit éclairage de secours
Turvavaloyksikkö

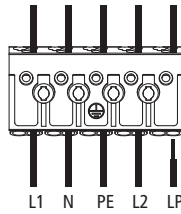

EVG getrennt schaltbar
HF switched separately
Commande conduite avec
capteur ou écran tactile DIM
Ilmais ohjau tai touchDIM

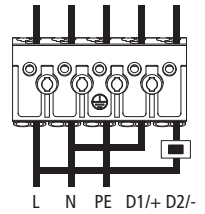

EVG getrennt schaltbar
HF switched separately
Balasto electrónico conmutada por separado
Balasto electrónico commutato separatamente
Ballast électronique commandés séparément
HF-liitäntälaite kytkeä erikseen

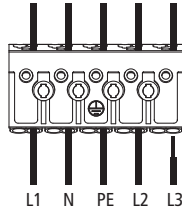

EVG dimmbar (DALI / 1-10V)
HF ballast dimmable (DALI / 1-10V)
Balasto electrónico regulable (DALI / 1-10V)
Ballast électronique graduable (DALI / 1-10V)
Reattore elettronico dimmerabile (DALI / 1-10V)
HF-liitäntälaite himmennettävä

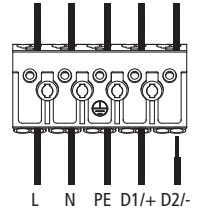

Information
Information

Información
Information

Informazioni
Tideot

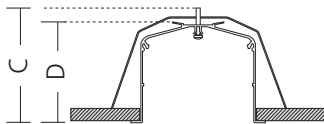

G – Gewicht / Weight
Peso / Poids
Peso / Paino

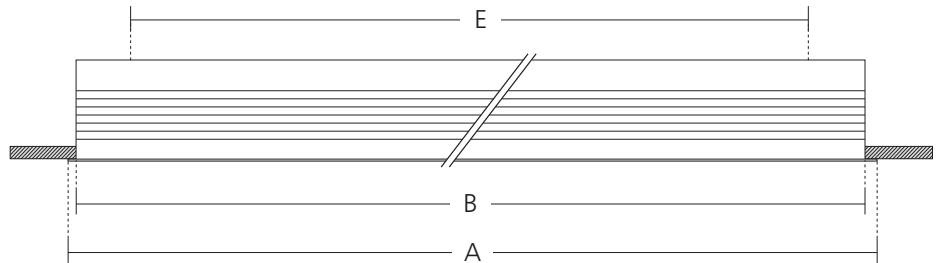

	A	B	C	D	E	G
T16 1 x 14 / 24 W	620 mm	607 +/- 2 mm	115 +/- 2 mm	90 mm	300 mm	2,5 kg
T16 1 x 21 / 39 W	920 mm	907 +/- 2 mm	115 +/- 2 mm	90 mm	600 mm	3,5 kg
T16 1 x 28 / 54 W	1220 mm	1207 +/- 2 mm	115 +/- 2 mm	90 mm	600 mm	4,5 kg
T16 1 x 35 / 49 / 80 W	1520 mm	1507 +/- 2 mm	115 +/- 2 mm	90 mm	900 mm	5,0 kg
T16 2 x 28 W	1220 mm	1207 +/- 2 mm	115 +/- 2 mm	90 mm	600 mm	6,0 kg
T16 2 x 35 W	1520 mm	1507 +/- 2 mm	115 +/- 2 mm	90 mm	900 mm	7,0 kg